



# INSTALLATION AND OPERATION MANUAL



## Batteries for electric drive of bikes

**EVBAT48V9A-R**  
**EVBAT36V13A-R**



Thank you for purchasing EVBIKE product and we hope that you will become a happy user.

**Carefully read the entire manual prior to installation and first use!**

If you find any fact in the manual that would prevent you from using our product, please contact your reseller for further discussion and keep the original packaging. The reseller will advise you how to proceed properly.

**Table of Contents:**

- Product Specifications
- Installation (before first time use)
- Control
- Error Messages
- Using the Battery
- Safety Precautions and Instructions for the End Consumer

**Note:** This user manual was translated from the Czech original.



## PRODUCT SPECIFICATIONS

EVBIKE batteries use specially designed traction cells SAMSUNG SDI that result in a superb drive power with a long life. Some further technical parameters of our product are shown in the table below.

<b>Specifications</b>	<b>EVBAT48V9A-R</b>	<b>EVBAT36V13A-R</b>
Nominal voltage	<b>48V</b>	<b>36V</b>
Nominal capacity	<b>8,8Ah / 423Wh</b>	<b>13Ah / 468Wh</b>
Typical capacity *	<b>8,2 Ah</b>	<b>12,35 Ah</b>
Recommended discharge current	<b>4 A</b>	<b>4 A</b>
Permanent discharge current	<b>15 A</b>	<b>15 A</b>
Peak discharge current (< 5 sec)	<b>25 A</b>	<b>21 A</b>
Minimal voltage (protection)	<b>37,7 V</b>	<b>29 V</b>
Charging voltage	<b>55,0 V</b>	<b>42,0 V</b>
Charging current	<b>2 A</b>	<b>2 A</b>
Time to charged condition (95%)	<b>5 h</b>	<b>7 h</b>
Spontaneous loss of capacity	<b>&lt;15% / 30 days</b>	<b>&lt;15% / 30 days</b>
Number of cycles**	<b>&lt;600</b>	<b>&lt;600</b>
Without any memory effect	<b>yes</b>	<b>yes</b>
Type of Samsung cells	<b>18650/2200</b>	<b>18650/2600</b>
Number of cells	<b>52 (4P13S)</b>	<b>50 (5P10S)</b>
Dimensions (length x width x height):***	<b>46 x 16 x 50 cm</b>	<b>46 x 16 x 50 cm</b>
Weight (without carrier/with carrier)	<b>4,7/5,6 Kg</b>	<b>4,7/5,6 Kg</b>
Type of battery case	<b>for carrier rack</b>	<b>for carrier rack</b>

\* A typical capacity for an aggressive discharge of a permanent discharge current.

\*\* After 600 normal cycles (i.e. discharge from 100 to 50% of the capacity) the battery still has minimally 70% of its original capacity.

\*\*\* The dimensions including bike carrier rack.



## INSTALLATION (BEFORE FIRST TIME USE)

Before first time use charge the battery to the full capacity (see chapter Using the Battery). The first process of charging may take a longer time due to balancing the voltage in the individual cells. Please do not disconnect the battery before the indication LED lights green.

## INSTALLATION OF THE BATTERY CARRIER

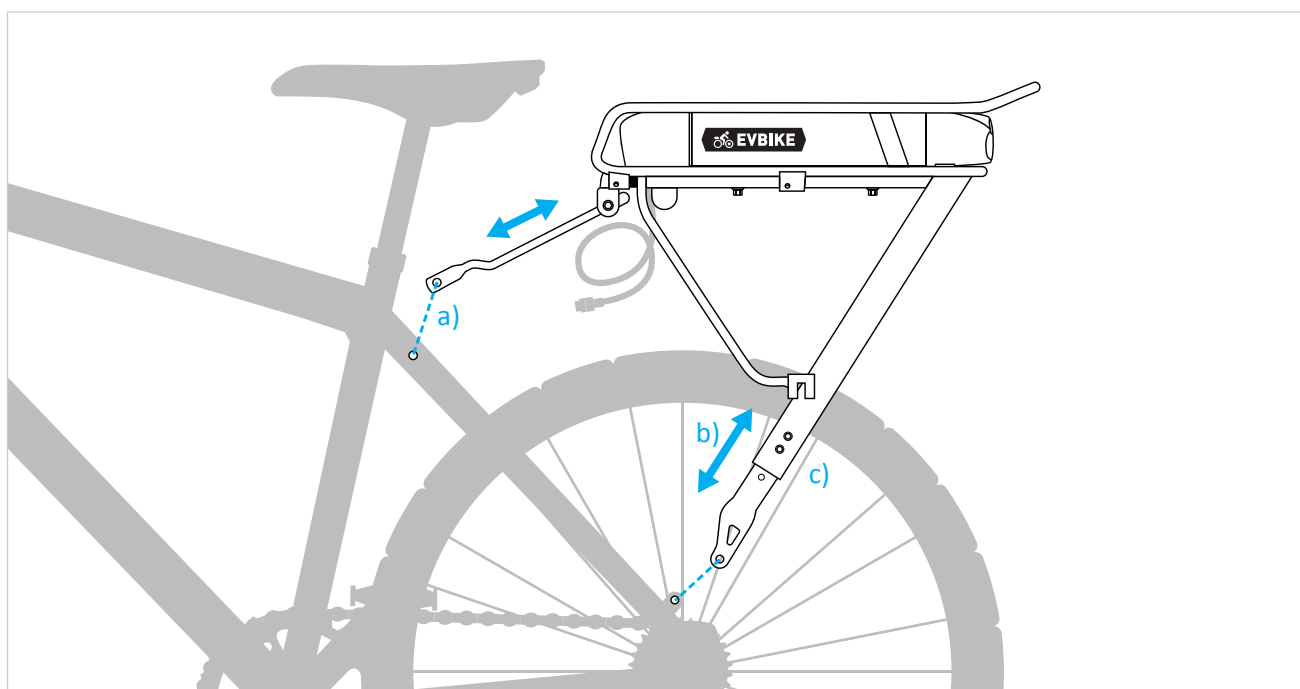
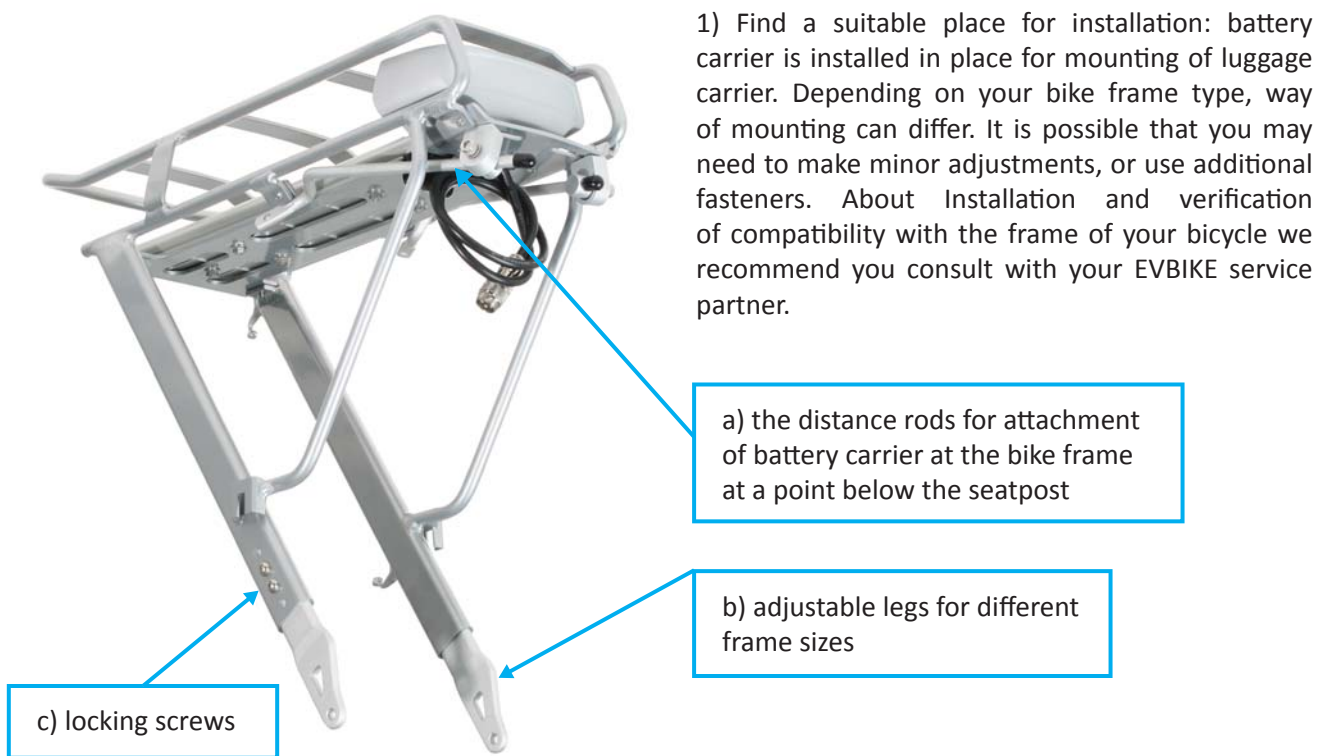

2) After adjustment of the spacing rods and the support legs according to the size and way of mounting on frame, screw bracket firmly to the bike frame. We recommend retaining screws to have affixed with adhesive against loss due to vibration.

3) Connect the battery carrier to the engine control unit using the cable with screw connector. Always ensure the correct polarity. Insert battery to the carrier. See the next chapter in this manual.

**WARNING:** Carrying capacity of the battery carrier is limited to 25 kg. Never overload a carrier or don't use for transporting people. This could damage the transported objects, accidents and injuries!

## CONTROL

### 1. Switching ON and OFF:

To activate the battery (ON), press the rocker switch on the underside of the battery. Active output voltage of the battery is indicated by LED diode on the switch.

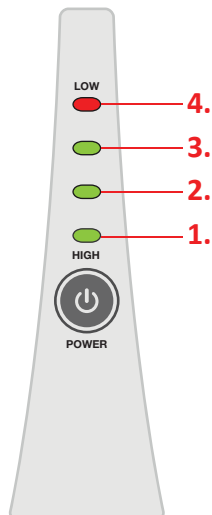

### 2. Finding out the charge status:

In order to find out the approximate charge status of the battery shortly press  button. The respective number of LEDs light on based on the current status of discharge. The number of LEDs that are on shows the status of discharge. In case that only LED 4 is on it is necessary to charge the battery.

LEDs on	capacity
1, 2, 3, 4	75 - 100%
2, 3, 4	50 - 75%
3, 4	25 - 50%
4 (red)*	0 - 25%

\*LED 4 always lights red even when the battery capacity is 100%.

### 3. Removing and inserting into the battery carrier.

Make sure that the lock is in the open position and by the pressure towards the seat insert the battery into the carrier. To remove the battery from the battery carrier, proceed as follows. In the unlocked position, grasp the battery at the end and pull backward to remove it from the carrier.

The first few insertions the battery into the carrier may pose a slight resistance, until mutual wear of contact surfaces of battery and carrier will occur. After some time, will be possible easily insert and remove the battery from the carrier.

To unlock the battery lock, turn the key counterclockwise. In the unlocked position, you can not remove the key from the lock. Turn the key clockwise to lock, thus ensuring eject from the carrier (in this position the key can be removed). When driving and manipulating always remove the key to prevent the accidental loss of or damage to break the lock.

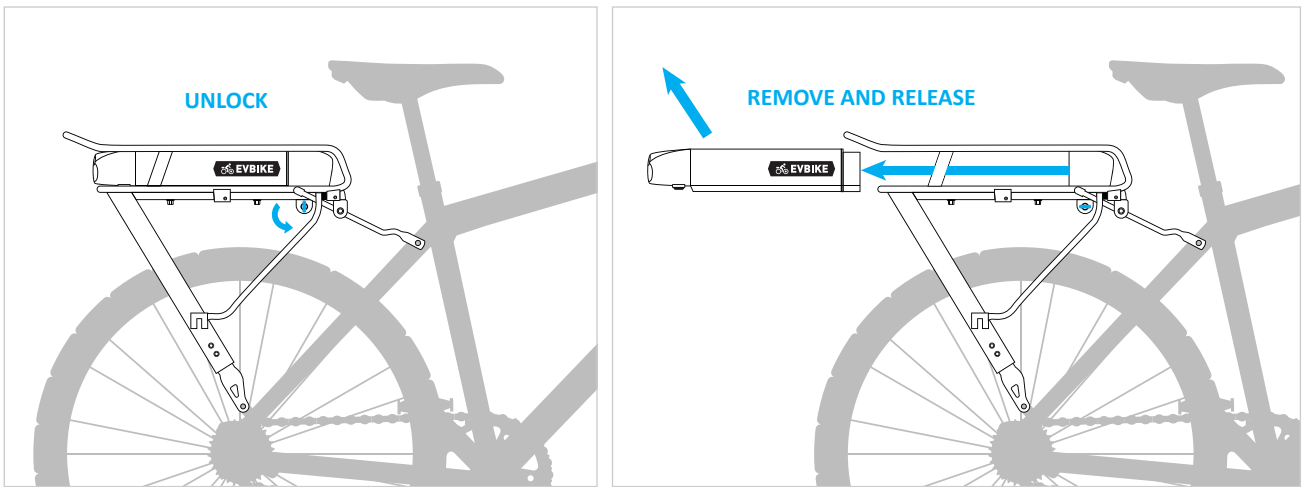

**WARNING:** During any ride the battery must always be locked and the key must be away of the lock.

### 3. Description of parts of the battery

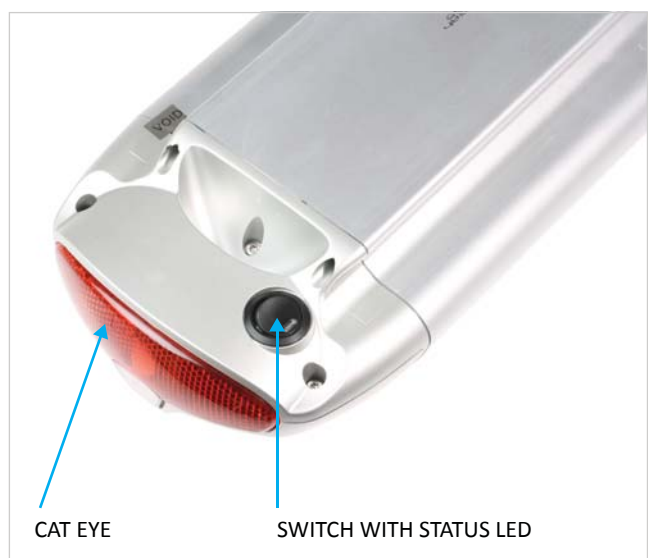
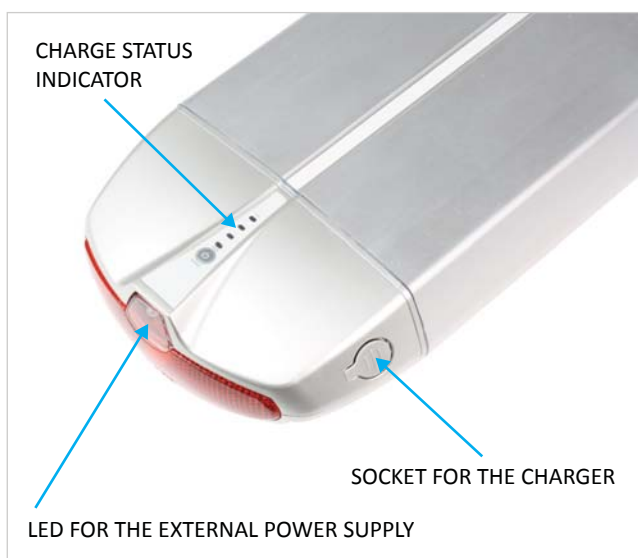



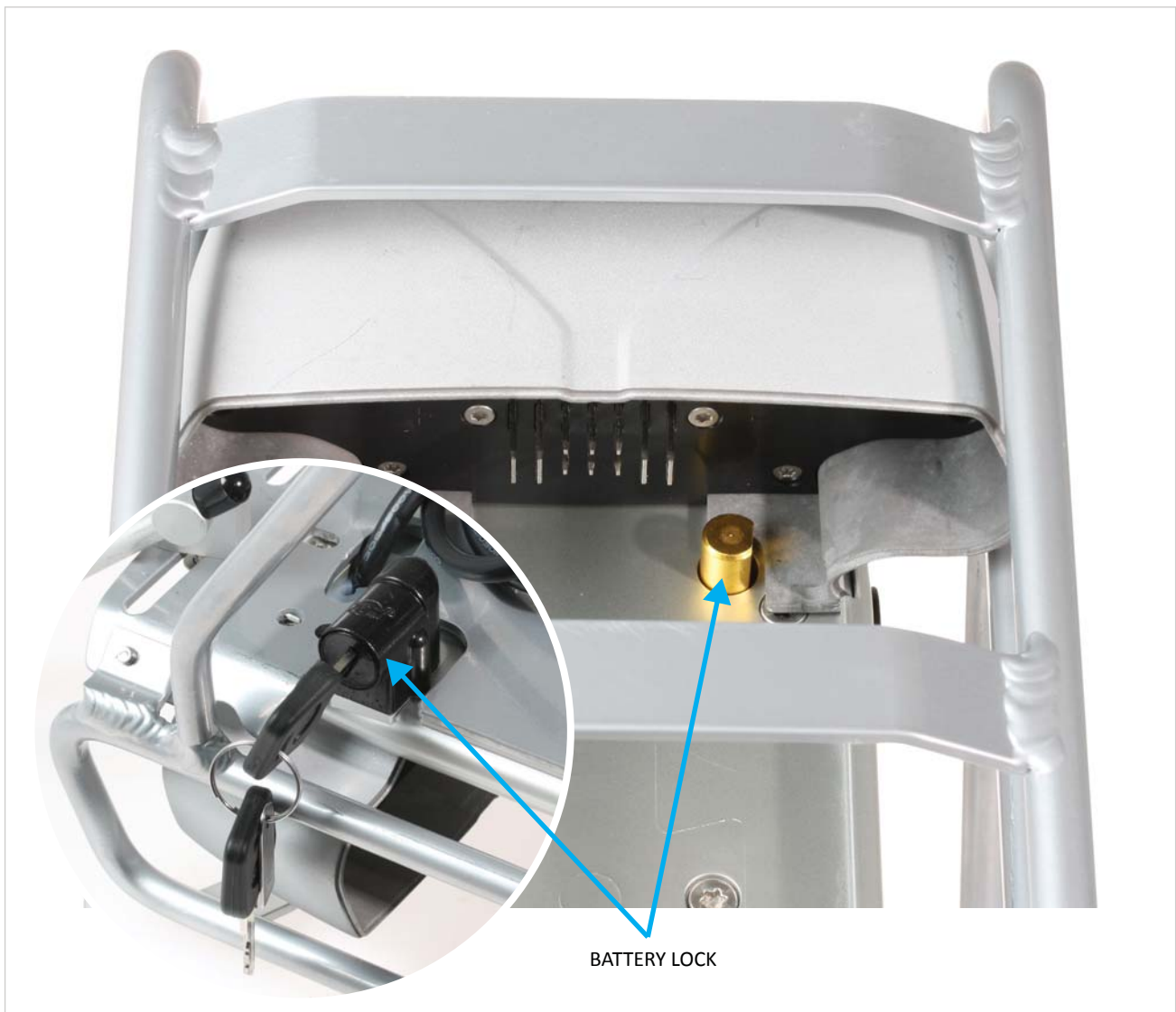
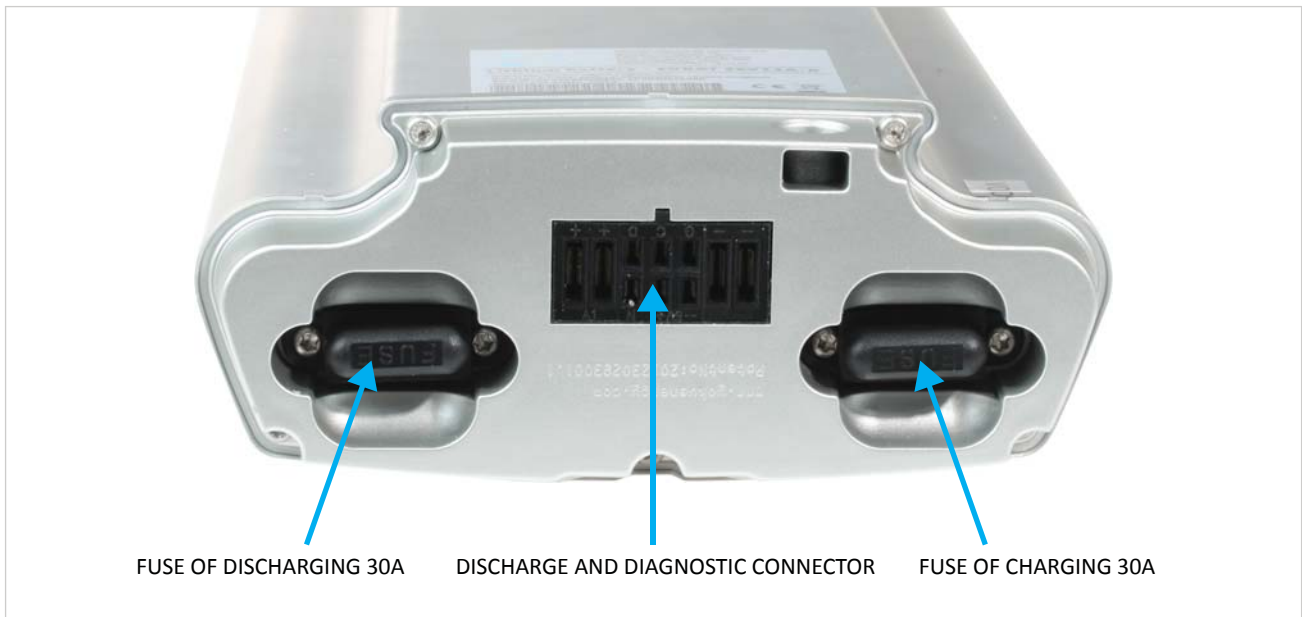

The battery is equipped with a built-in LED for the external power supply. LED serves as a marker light for night lighting. Due to legislative decree must be lighting provided independently of the main battery. The power supply of LEDs can be implemented using an external source 6V.



If you want to use the LED light, proceed as follows:

- a) Disassemble "controller box" on the battery bracket, which contains discharge connector.
- b) Connect the wires with a external power supply of 6V as shown in Figure below.

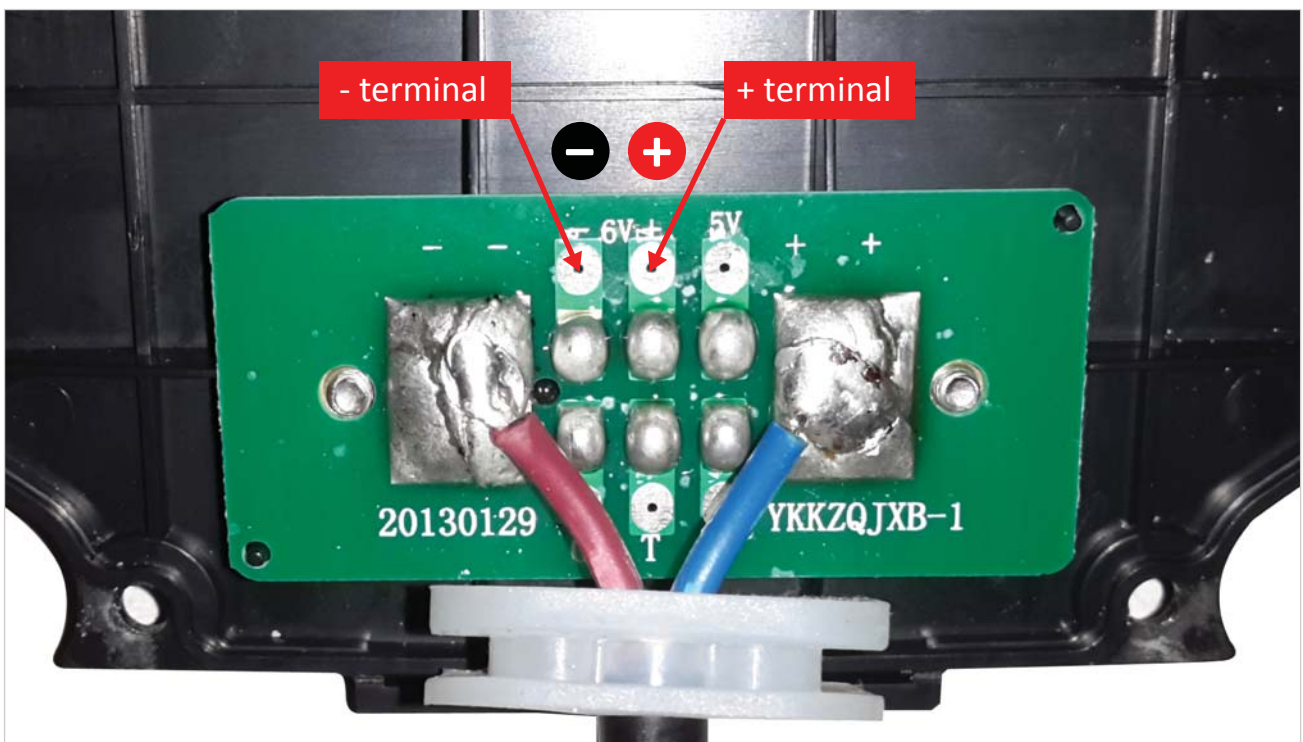



## ERROR MESSAGES

Thanks to an intelligent circuit controlled by a microprocessor (so-called BMS) the battery can record many values and based on them evaluate different risks. In case there is a risk of damaging the cells based on critical operation values (high temperature, extremely high current) the battery is blocked for further use. In most cases it is fine to leave the battery outside of the bracket and when the values are acceptable again the battery unblocks itself for further operation. Typically it is an overheated battery due to direct sunshine or overcharging cells in the process of recuperation of braking energy to a fully charged battery.

While considering the above if it is still not possible to switch the battery on and normally use, please check the following messages using the status LEDs.

		LED4 (red)	LED3 (green)	LED2 (green)	LED1 (green)
1	defective charger	-	flashes	-	-
2	deep discharge	-	-	flashes	-
3	defective cell	-	-	-	flashes
4	misbalanced cells	-	-	flashes	flashes
5	high load	flashes	flashes	-	-

### Meaning of the individual faults and possible solutions:

1	Defective charger or BMS module of the battery. Please try to replace the charger. If charging the battery is still impossible, contact a service.
2	Deeply discharged battery due to an improper maintenance by the user. It is necessary to store the battery charged to at least 75% of its capacity. Deep discharge may cause entire damage to the battery cells. Switch the battery off (the red and green LEDs flash). Connect the charger and leave it connected for at least 3 hours. If charging does not start and the problem persists, contact an authorized service for diagnostics and repair.
3	One or more cells are defective. Switch the battery off (the red and green LEDs flash). Connect the charger and leave it connected for at least 3 hours. If charging does not start and the problem persists, contact an authorized service for repair.
4	The cells are misbalanced. Switch the battery off (the red and green LEDs flash). Connect the charger and leave it connected for at least 3 hours. If charging does not start and the problem persists, contact an authorized service for repair.
5	Weak or defective cells. Excessive load of the battery – short circuit protection. If in the course of 15 minutes BMS records more than 8 times disconnection due to overloading, then BMS reports an error. Please check the connection of the battery and the cable of any breakage. Furthermore, check the system settings whether the recuperation (regeneration of the braking energy) is not active and disable it if needed.

## USING THE BATTERY

### 1. Proper charging:

Lithium cells SAMSUNG SDI that are used in EVBIKE batteries can be charged in any status of discharge and these batteries do not have any memory effect. That is why we recommend always charging the battery after a ride or in the course of a longer break so that you can enjoy a full power and long reach. When the charging is completed, always disconnect the battery from the charger. Charge the battery only in a room temperature (25 °C). Use solely the charger supplied with the battery and make sure that it is not confused with another charger. Never use a charger with damaged case or supply cable – risk of electric shock. Do not charge where the temperature is below freezing point and on the contrary batteries on excessive sunshine.

The charging status is shown by the LED on the charger:

- Red – process of charging.
- Zelené světlo – nabíjení dokončeno (nabíječka je automaticky odpojena od baterie)

The duration of charging is 5 - 7 hours depending on the status of discharge of the battery and its capacity.

### 2. Proper discharging:

Charge the battery to the full capacity after the first disconnection by protection of the control unit. Never try to use the battery again after it is disconnected by the protection. You will not only get any further but some of the cells may be deeply discharged, leading to their irreversible damage. Such a behavior results also in "misbalancing" of voltage in the individual cells, resulting in a lower capacity of the battery. In extreme cases it will not be possible to recharge the battery. Such damage can be easily diagnosed and faults resulting from such a behavior are excluded from warranty.

### 3. Storage:

If you do not use your bike for over an hour, the battery enters sleep mode. It is not necessary to switch the battery off in everyday use. It is only necessary to recharge it. If you are not going to use your bike for longer than 48 hours always take the battery out, recharge it and store on a dry and safe place at room temperature. Be careful to avoid shorting the terminals (contacts) of the battery when storing or manipulating with it. For a long-term storage, for example due to off season (anytime the battery is not to be used for at least 7 days), it is necessary to switch the battery off (see chapter Control) and every 30 days check the battery (using the indication LEDs). If there is a decrease of energy, recharge to 75% of capacity. Recharging to 75% means that on the charge status indicator LEDs 4, 3, 2 are on and LED 1 flashes. Now is the time to disconnect the battery from the charger. Do this control charging every month. If you store a discharged battery, there is a risk of deep discharge of cells and their irreversible damage and such a fault is excluded from warranty.

period of not using the battery	storage	charging
1 – 48 hours	I can leave the battery in the bracket on my bike, placed in a dry environment with room temperature	recharging to 100%
2 – 7 days	I store the battery in a dry environment with room temperature	recharging to 100%
7 and more days	I store the battery in a dry environment with room temperature	recharging to 75% and I control the charge status every 30 days



# SAFETY PRECAUTIONS AND INSTRUCTIONS FOR THE END CONSUMER

## 1. Warranty:

The warranty for quality relates to any manufacture defects that the battery provably demonstrated already at the time of delivery and to the nominal battery capacity at the time of the delivery. The warranty relates to normal operation functionality within the specifications given by the producer. The guaranteed nominal capacity of the battery is achieved by discharging by the recommended discharge current based on the type of the battery and temperature of 25°C. The warranty does not include any drops of cell capacity within the tolerance given by the producer in the form of the number of charging and discharging cycles. The warranty applies neither to any defects resulting from some mechanical damage, use outside the permitted range of the discharge and charge current and voltage, unintentional short circuit, unintentional discharge, i.e. when the battery is left over 14 days without any control, nor to any damage caused by leakage of liquids nor by using it or storing in a humid environment. One of the conditions for granting any warranty is keeping all recommendations mentioned in this manual. The duration of warranty is stated on the delivery note of the reseller.

## 2. Using the battery – possible dangers:

- **Danger of short circuit and subsequent fire.**

Both charged and discharged cells contain a large amount of electric energy that may cause electric sparks or electric arc if the contacts are shorted. The red-hot contacts may ignite other flammable materials.

- **Danger of injury by direct current.**

If there are a larger number of cells connected as a series, there is a higher danger of injury by direct current. Never ever touch the electric wires or other components with voltage.

- **The danger of chemicals.**

Lithium cells and batteries do not contain any corrosives or acids. Still they contain chemicals that may affect human organism. That is why it is necessary to keep in mind the following principles when manipulating with the cells and batteries:

- a) Eye protection: protect your eyes with glasses to prevent any chemicals from getting to your eyes.
- b) Skin protection: use protective clothing and gloves. Prevent your skin from any contact with the chemicals.
- Protection against inspiration: work with the batteries only in a well ventilated place. In a closed environment it is necessary to provide forced ventilation.

## 3. Instructions for the End Consumer:

The battery can be used only by a person who has been properly instructed about using the lithium cells and batteries. This instruction must be provided by the last seller. In case of a distant sale, this instruction is done by attaching a manual. Further information regarding using the battery can be found on the website of the reseller.

## 4. General rules for using and storing batteries:

- Protect from unqualified manipulation.
- Avoid polarity mismatch, heed the signs when inserting. Reverse insertion of the battery may result in short circuit or charging.
- Avoid short circuit. Short circuit results from connecting positive (+) and negative (-) terminals of the battery.
- Prior to installation clean the pole terminals of both the battery and the device.
- Avoid excessive heating – operate the battery only at a temperature based on the concrete specification.
- Do not weld or solder the cells.
- Do not dismantle. If uncovered, the contact with the individual parts of the battery may be harmful.



- Do not deform. The batteries should not be pressed, pierced etc.
- Do not dispose of in fire.
- Do not expose to water or excessive humidity
- Do not keep within the reach of children. Especially batteries that could be swallowed need to be kept out of their reach. Also children must not be allowed to replace the batteries without the supervision of an adult.
- Do not encase or do any other modifications. Encasement or any other modification to the battery may cause blockage of the safety ventilation mechanism. Any modifications need to be consulted with the reseller.
- Batteries that are not used need to be stored charged and kept out of reach of any metal subjects that could cause short circuit. The pieces that are already unpacked should not be mixed and stored together.
- Avoid extreme humidity (over 95%). High temperature or humidity may impair the characteristics of the battery and/or the corrosion of its surface.
- Do not store / expose the battery to the direct sunshine, places exposed to rain, excessive heat, in proximity of radiators or water heaters.
- Store the batteries in a well ventilated and dry environment, ideally enclosed in a protective package.
- When storing, keep the temperature within the range specified for the specific cell
- Do not mix it with some other materials.
- Do not stack the cardboard boxes with the batteries. Stacking could lead to deformation of the batteries in the lower layers and subsequent electrolyte leakage.
- For any further transport / manipulation choose such a packaging material and method of packing that would prevent from creating an unintentional electric contact and corrosion of the terminals, assuring protection from the elements and any mechanical damage.
- Manipulate with the boxes considerately. Coarse manipulation may cause short circuit or damage.
- Keep a proper circulation of supplies, keep the FIFO system.
- Store the batteries charged and take a measure of their voltage every 2 months. If the value is near its minimum, recharge the battery.
- Operate the batteries under supervision or under a constant monitoring by a protection and control system. Avoid overcharging and total discharging.

## 5. Recycling the batteries and cells, mandatory information required by law, declarations of conformity

a) regarding the way of providing take-back or separated collection; for this purpose, in a way available for the end user, the producer publishes a current list of take-back and separated collection locations with at least a name of the place and its address.

**Take-back and separated collection location i4wifi a.s., Průmyslová 11, Praha 10**

b) regarding any negative effects of materials used in the batteries to the environment and human health

**The batteries and cells contain chemicals that may have negative effects to the environment and human health.**

c) regarding the meaning of the symbol for take-back and separated collection and regarding the meaning of marking.



**THIS IS THE SYMBOL FOR TAKE-BACK OR SEPARATED COLLECTION.  
DO NOT THROW THE BATTERIES TO HOUSEHOLD WASTE, THEY NEED TO BE  
RETURNED AT A TAKE-BACK AND SEPARATED COLLECTION LOCATION.**



d) declarations of conformity:

Global World Logistic Ltd., EU-VAT ID: CZ682998344, as an entity authorized by the producer for EU, thus proclaims that the device conforms to basic requirements and any other relevant provisions of Decree-Law No 17/2003 Coll. establishing technical requirements for low-voltage electric devices (or LOW VOLTAGE DIRECTIVE 2006/95/EC). This statement is issued on the basis of documents presented by the producer.

